

TMA#01

This TMA will form the basis of a design project which will be completed within TMA 2. You should therefore think carefully about which of the following Case Studies you choose, based on your knowledge of the theory and practice of the product chosen.

For **ONE** of the case studies given on the next page, complete the following.

1. Derive at least four concept designs to satisfy the given specification. Use short written descriptions and simple sketches to illustrate your ideas. Show evidence of the use of the following techniques:
 - brainstorming
 - synectics
 - morphological chart.
2. Use the weighted objective method to select **your** best solution from any **four** of the concept designs.
3. What other information would be required to be able to write a more complete Product Design Specification? (Use an objective tree to clarify and expand upon the vague brief given.)

Case Studies

Choose **ONE** of the following.

- (a) As a keen, but economically challenged, cyclist you need a means of carrying two bicycles whilst travelling between destinations on a touring holiday in your small car which has a tow bar fitted.

OR

- (b) It has been found that to improve product quality, a process stream leaving a storage vessel on a chemical plant now needs to be cooled from a temperature of 100°C to a temperature of 50°C before entering the reactor. The ambient air temperature averages 15°C with a high of 25°C. A water supply at 40°C is available.

OR

(c) An analogue/digital circuit trainer is required for students to construct circuits. The design requires:

- the ability to build circuits
- associated power supply
- a suitable waveform generator
- a means of measuring current, voltage and resistance.

TMA#02

1. Following on from the first TMA in this module, produce a design report for **ONE** design of the product based on ONE of the scenarios covered on the following pages. The report should contain, where appropriate:

- Title page
- Acknowledgements
- Summary
- Contents
- Introduction
- Basic Product Design Specification
- Design Parameters
- Simple Description of chosen Design
- Design Evaluation
- Detailed drawings of the design, including dimensions, such that its constructional features can be seen*
- Conclusions
- References
- Appendices.

*Drawings should be submitted as complete engineering drawings done using MicroStation (or other CAD software). If the maximum size of printing is A4 then several sheets, each showing a different view of the design, will probably be needed to show sufficient detail for the design to be constructed. In this case, all views should be clearly labelled and all sheets numbered. Only computer-produced drawings will be marked: it is not acceptable to submit hand-drawn work. You should therefore submit the computer files along with the printed hard copy.

Note: you may have to invent information to make the Report complete.

2. Having used MicroStation (or other CAD software) as part of your Design Report, evaluate its value TO YOU in terms of:

- costs
- functionality
- compatibility.

SCENARIOS

Either

(a) Bicycle Rack

When a full design specification was produced and the weighted objective procedure carried out, it was found that a tow bar mounted rack was the best solution. This would bolt to the tow bar once the tow ball has been removed.

The dimensions of the tow bar bracket are as shown in FIGURE 1. The 330 mm dimension refers to the distance from the ground to the bottom of the bracket. In order to avoid the bikes fouling the car, it should be assumed that no part of either bike should protrude beyond the face of the tow bar bracket.

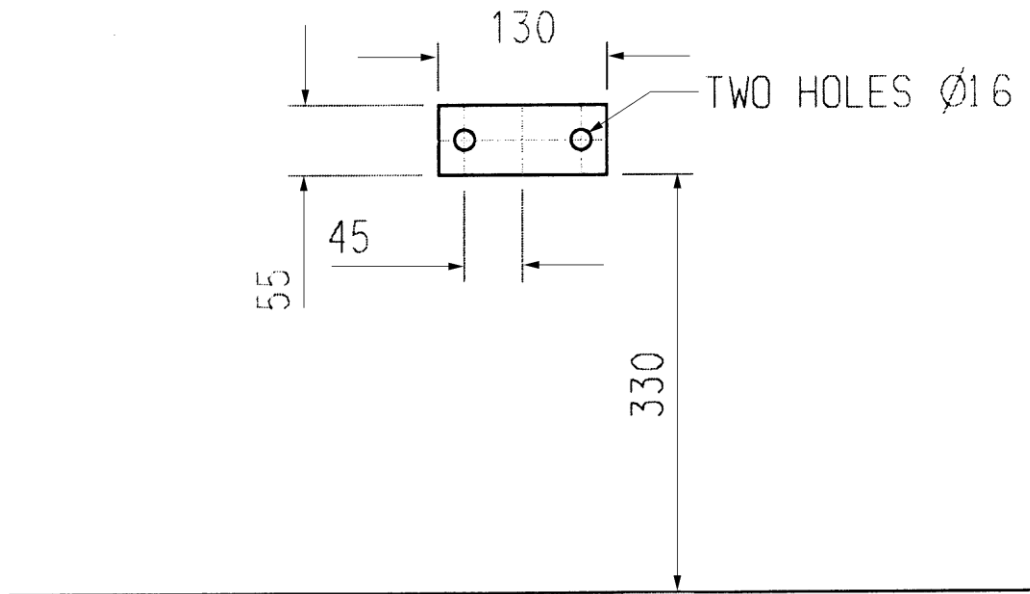

FIG. 1

The two bikes to be carried have the dimensions shown in FIGURES 2 and 3. The width of the handlebars of the man's bike (FIGURE 2) is 420 mm whilst that of the lady's bike (FIGURE 3) is 630 mm. The width across the pedals is 360 mm in both cases.

Your good friend Fred has offered to help build the bike rack and he has access to the following materials and equipment:

Square section steel tubing 25 mm × 25 mm, 2 mm thick

Steel plate 8 mm thick

Steel strips 25 mm wide by 6mm thick

Brazing and welding gear

A powered hacksaw

A Pillar drill.

Design a suitable rack that can be made using Fred's materials and equipment. It is not necessary to worry about stresses, the materials are capable of exceeding the strength requirements of any design, and the rack should be designed to 'look right'.

As part of the Design Report, you should produce:

- (i) An arrangement drawing showing the outline of the bikes on the rack. This does not need to be very detailed or show any dimensions but should clearly demonstrate that the rack will enable the two bikes to be carried without fouling the car or the ground.
- (ii) A detailed engineering drawing of the rack only, showing front and side views with all dimensions required for manufacture shown on them.

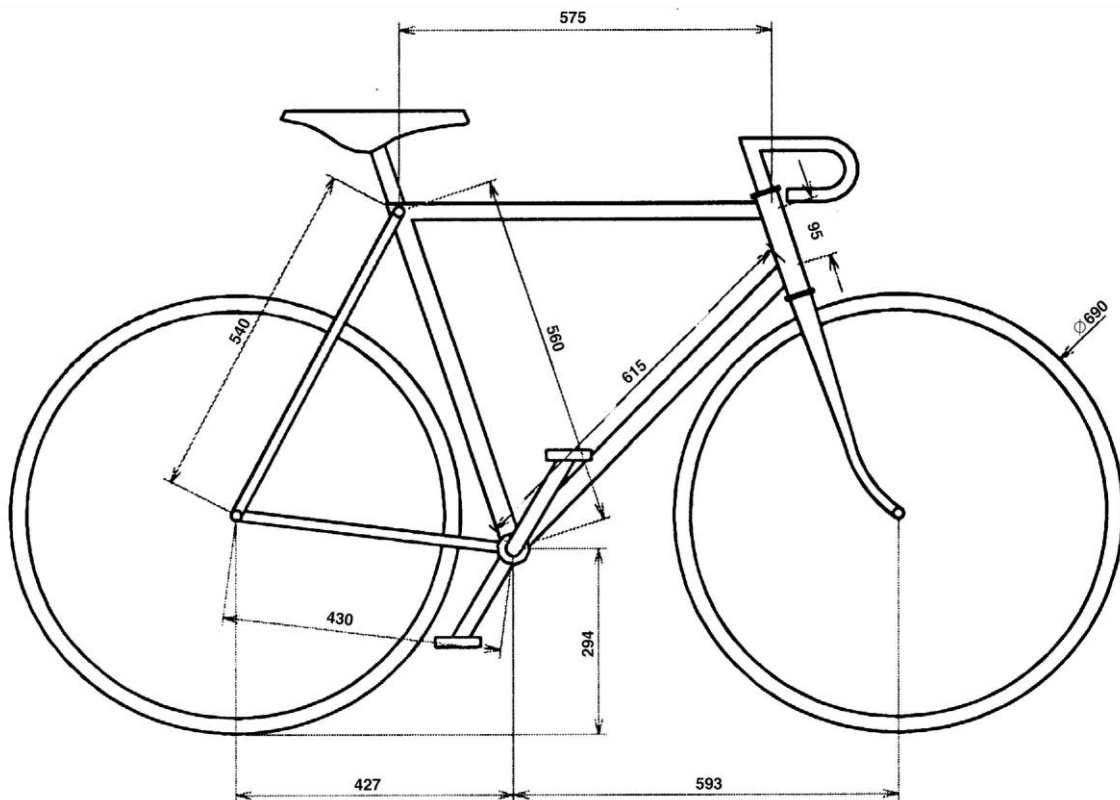

FIG. 2

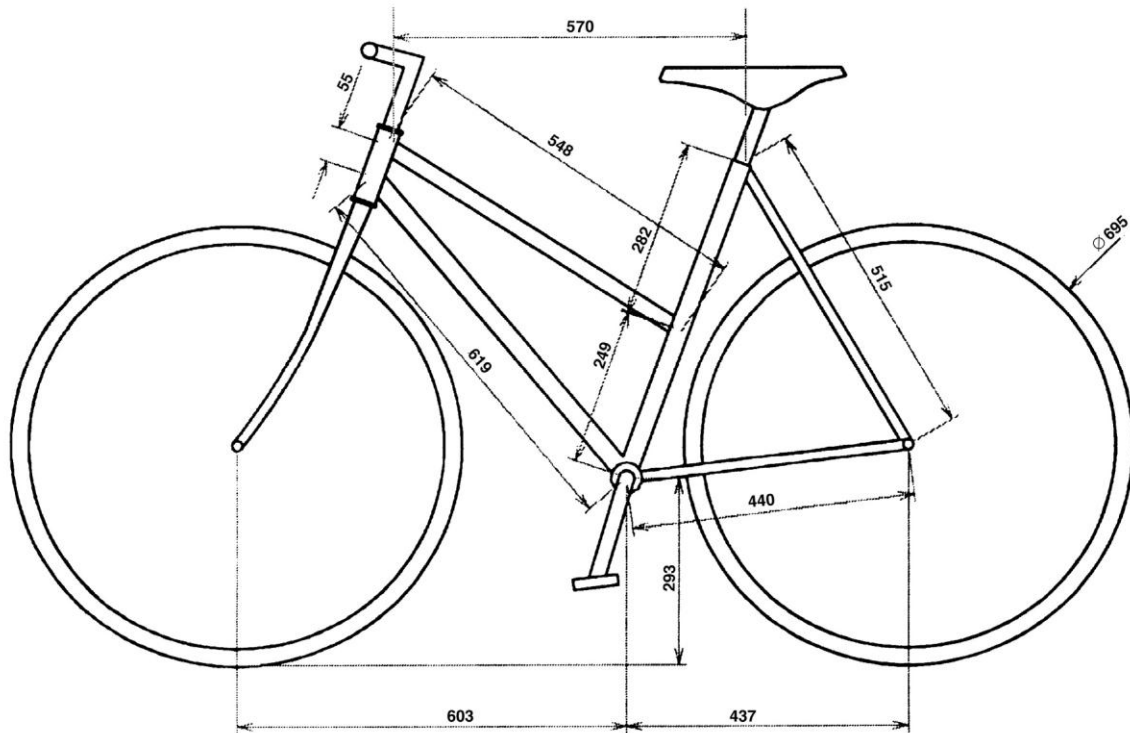

FIG. 3

OR

(b) *Heat exchanger*

Based on a full Product Design Specification, the shell and tube heat exchanger to be used will replace part of the pipe connecting the existing reactor feed inlet and the storage tank. This pipe is an 80 mm internal diameter pipe which has a wall thickness of 4 mm. The connections required on the heat exchanger will have the same internal diameter and wall thickness as the pipe and are to be made using flanges which are 150 mm diameter, 15 mm thick and joined to an identical flange on the pipe using 4 M10 nuts and bolts equally spaced with centres 15 mm from the circumference of the flange.

The maximum horizontal space between the storage tank and reactor inlet is 7 m.

The large amount of cooling required means that water (rather than air) will need to be used for the cooling and this is to be supplied via a 42 mm internal diameter pipe, wall thickness 4 mm, fitted with a 100 mm flange, 10 mm thick with 4 holes equally spaced with centres 12 mm from the circumference to allow M8 nuts to be used for the connection to a similar pipe and flange on the water pipe. For higher efficiency, the water will flow in the shell counter current to the process fluid within the tubes.

96 tubes are required of 12 m length to give the required heat exchange surface area and each tube will need to be 20 mm internal diameter (to maintain the required flow velocity of process fluid), of 4 mm wall thickness (for strength) and at centres 50 mm apart. Square pitch is to be used to enable easier cleaning. The tube headers are semi-spherical of diameter D (the diameter of the shell) and 10 mm wall thickness. The tube plates are 6 mm thick.

The total shell area per tube pass is to be 0.2618 m². Four shell side baffles are required to maintain the required water flow velocity and level of turbulence. The baffles will be equally spaced and will be of height $0.7D$ (D = diameter of shell).

The baffles and any pass partition plates used will be 5 mm thick to give them the required strength.

For safety reasons, the shell will be covered by 100 mm of lagging.

You will be required to draw a central cross-section of the heat exchanger and a view of the tube plate at either end of the exchanger.

OR

(c) *Front Panel of Circuit Trainer*

An analogue/digital circuit trainer is required for open learning students to use to build circuits as part of their electrical/electronic practical work.

The circuits that are to be built can consist of up to five integrated circuits and their associated discrete components.

FIGURES 4, 5 and 6 each show a block diagram for each system of the intended design:

(i) Power supply consisting of

- 240 V supply input
- Power 'on' indicator
- +5 V output
- +12 V output
- -12 V output
- 0 to +12 V variable output
- 0 to -12 V variable output
- Output short-circuit indicators for '+' and '-' supplies.

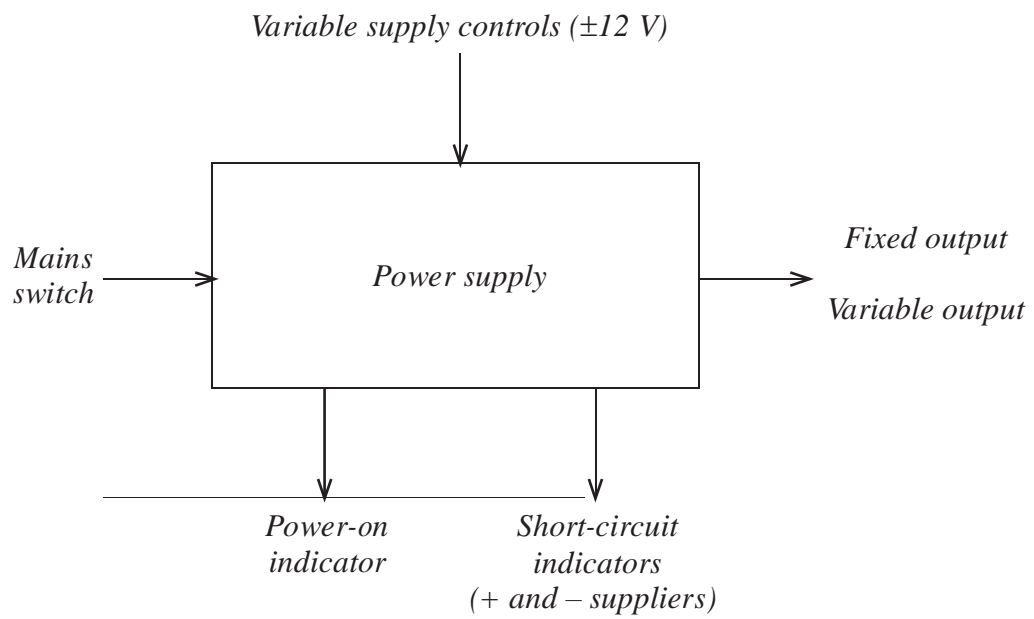

FIG. 4

(ii) Function Generator capable of

- generating sinusoidal, triangular and square waveforms
- variable amplitude
- variable frequency
- frequencies in the ranges 0 to 100 Hz, 100 Hz to 10 kHz and 10 kHz to 1 MHz.

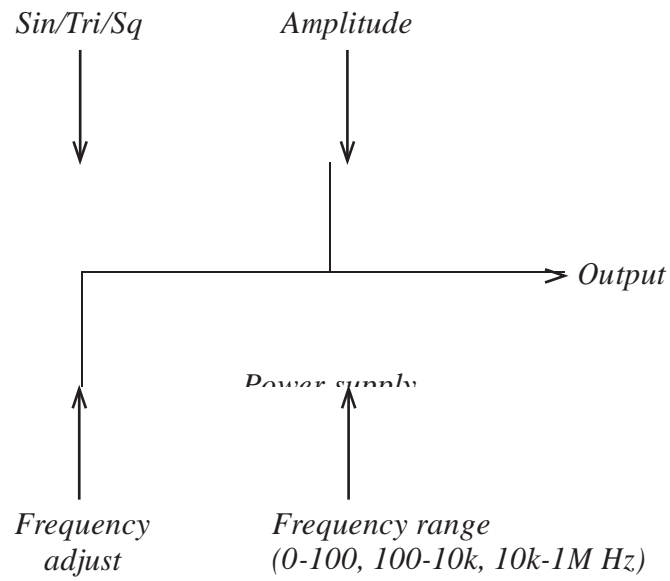

FIG. 5

(iii) Multimeter capable of measuring

- resistance
- voltage
- current.

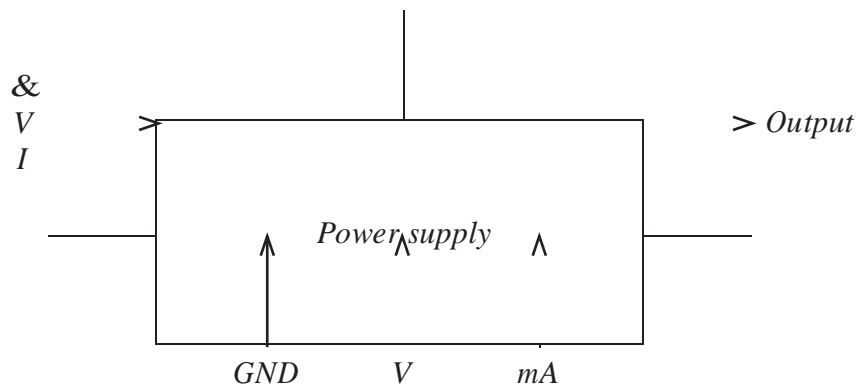

FIG. 6

You will be required to draw a plan view of the front panel to show the mounting of the various controls, etc. A photograph of an example of an existing circuit trainer is given in FIGURE 7.



FIG. 7

